

FRIALEN® Elbows 45° W45°

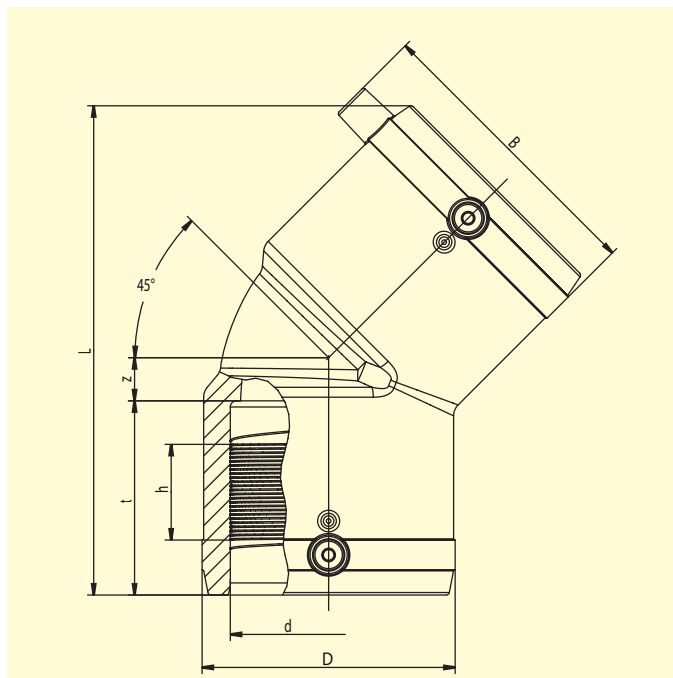

PE 100 SDR 11

Maximum working pressure 16 bar (water)/10 bar (gas)



d	Order Ref.	Stock-status	BX	PU	D	L	t	z	h	B	Weight kg/each
32	612092	1	45	1440	43	102	44	8	21.3	60	0,070
40	612094	1	25	800	54	120	48,5	11	28.7	70	0,110
50	612096	1	20	640	66	136	54	13	32.4	80	0,175
63	612098	1	10	320	82	158	62	14	33.6	95	0,295
75	612100	1	14	252	96	198	70	29	37.5	111	0,520
90	612102	1	8	144	115	232	79	35	45	128	0,810
110	612104	1	10	80	138	265	85	41	50.3	150	1,320
125	612106	1	10	80	157	279	87	46	43.5	167	1,770
160	615275	1	4	32	207	377	92	88	43.5	210	4,410
180	615687	1	3	24	228	382	97	83	65	229	4,610
200	616264	1	1	18	254	415	106	87	54	256	6,760
225	615688	1	4	32	280	450	112	98	66	281	8,290

FRIALEN-Safety Fittings can be fused to pipes of SDR stages 11 to 17.6
 DVGW-Registration Nos. DV-8601AU2248 and DV-8606AU2249

FRIALEN® Elbows 45° W45°

Areas of Application

The FRIALEN-Elbow W45° is used for all changes of direction in HDPE pipes.

Assembly Instructions

The fusion of the pipe ends with the FRIALEN-Elbows W45° takes place by FRIALEN-fusing – leakproof and longitudinally strong.

The pipe ends are prepared according to the general installation instructions (see Assembly Instructions for FRIALEN-Safety Fittings for house connections and distribution pipes up to d 225). This involves removing the oxide skin and cleaning the pipe ends.

Eleven good reasons for using the FRIALEN-Elbows W45°:

- Large coupler depth for ease of pipe guiding (no holding clamps required)
- Extra wide fusion zones
- Maximum stability through great wall thickness
- Cold zones at the front side and in the middle of the coupler
- Exposed heating coil for direct heat transmission to the pipe
- Small annular gap for build-up of optimum joining pressure in the fusion zone
- Contacts safe to touch
- Fusion indicator for visual fusion control
- Durable batch marking
- Individually wrapped for dirt protection
- Additional barcode for tracing back the fitting (Traceability-Coding)

For further information, please call our customer service staff and specialist advisers.

FRIATEC Aktiengesellschaft · Technical Plastics Division
 P.O.B. 71 02 61 · D-68222 Mannheim
 Telephone +49 621 486-1431 · Telefax +49 621 479196
 www.friatec.com · E-Mail: info-frialen@friatec.de

Please find our datasheets for downloading on the internet at www.friatec.com